

Breakdown and settlement

Trouble	Probable cause	Remedy
The machine can't run after switch on.	It is not good to touch electric.	Check the electric circuit.
	The belt damages.	Change the damaged belt.
Oil leakage.	The sealing round damages.	Change the damaged one.
The raising handle is too heavy	Orbit is erosion	Clean the damaged one.
	The up and down pole, cone gear and hand wheel axle are dry.	Put the lube.
The temperature of motor increases too high and the speed decreases.	Not enough voltage.	Check the voltage.
	Charge is too heavy.	Decrease burden.
	Working speed is too fast or it is not suitable for choosing agitator.	Choose a suitable position and agitator.
Choose a suitable position and agitator.	The lube is not good.	Put in or change the lube.
Agitator touches the sides	Agitator or bowl change the shape.	Correct or change the distortion agitator or material barrel.

B40/B40A/B40F/B40FA MIXER

USER MANUAL



INDEX

Introduction	1
installation and specification	2
Operation instruction	3
Bowl's up and down	4
Figure 1 Centre axle	5
Figure 2 Gear axle	6
Figure 3 Initiative axle	7
Figure 4 Motor	8
Figure 5 Fork	9
Figure 6 Speed shaft	10
Figure 7 Turning plate and mixing axle	11
Figure 8 Standard and accessories and electric diagram	12
Maintenance and protection	13
Breakdown and settlement	14

Maintenance and protection

1. When the machine is running, put hands and other things into the barrel are prohibited.
2. When the machine has worked for a long time, you must cool it down and re-start the machine.
3. It is not adaptable to run the machine for a long time continuously, make sure the machine can be used better and longer.
4. Pulling the gear and belt by hands is prohibited in order not to injure.
5. Clean the bowl and agitator or after use in order to keep health.
6. The up and down orbit(1) are added a little lube.
7. Hand wheel axle (2) shall put a glass of lube at a regular time.
8. All axletrees and gears have put into excellent lube. Usually, these spare parts can be used for half a year, and if you need to take apart them and put the lube, you can take apart the box cover and adding lube hole (3) of cover of shift box.
9. Take apart the ventilation cover, and put some certain lube to cone gear(4).
10. Check the belt loose or tight.

ATTENTION

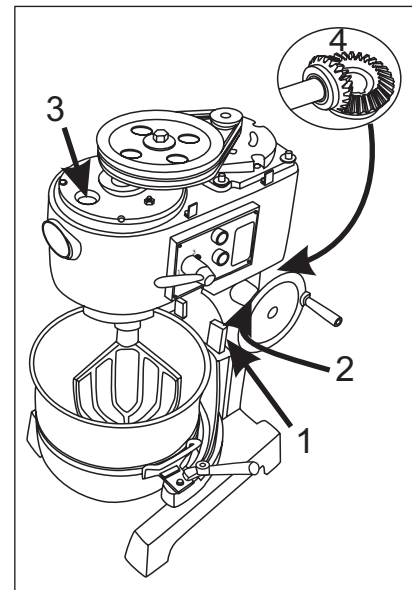

Warning

1. Clean and spray the mixer by water pipe is prohibited.
2. If you maintain the mixer, you must cut off the power source and ask the professional electricians to fix it.
3. Touching the electrical switch and power source by wet hand is prohibited.
4. When there are some damages in the machine, stop using it.
5. There is a equal potential connecting the ground in the mixer. When the machine needs to be repaired and be smooth to repair finally, you can not take off the ground wire.
6. Teenagers cannot be close to the mixer.
7. The mixer must fix on the dry wooden splint and there is safety-working zone in it.

FIGURE 9 STANDARD ACCESSORIES AND ELECTRIC DIAGRAM

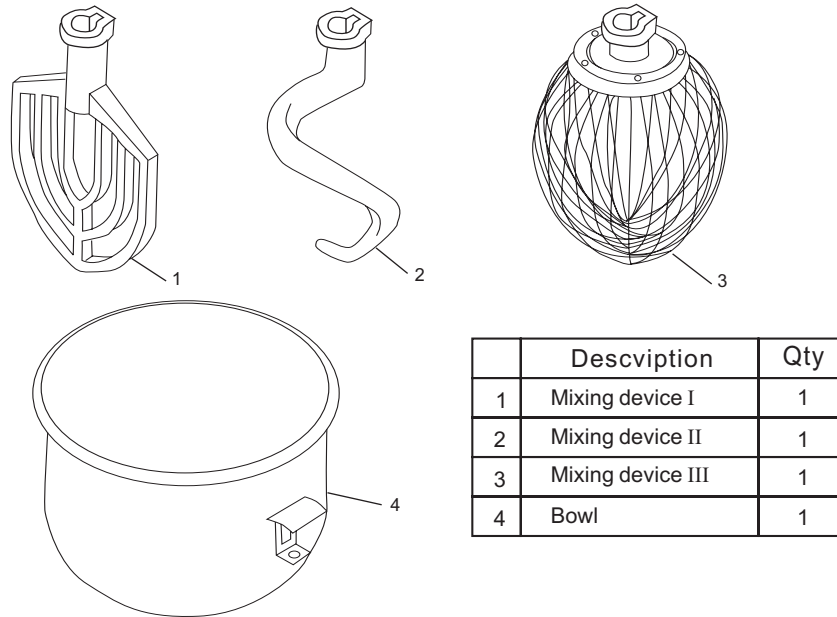

	Description	Qty
1	Mixing device I	1
2	Mixing device II	1
3	Mixing device III	1
4	Bowl	1

1 Phase Motor diagram:

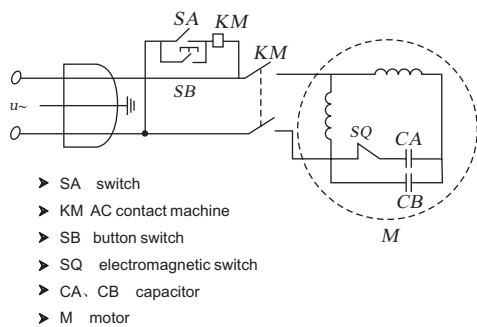

3 Phase Motor diagram:

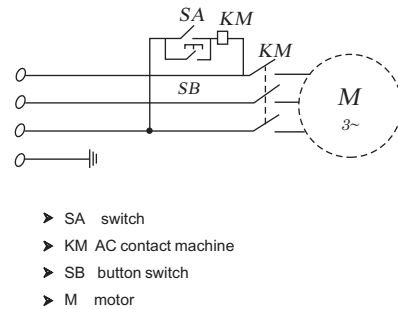

Introduction

The B40 food mixer is the new product of B series of Universal food mixer. It can mix, grind the flour and liquid food. The design is with belt and gear transmission. The mixer makes good use of planet principle, so the agitator runs in the material barrel just like the planet and it can mix food smoothly and fully. The machine runs with several speeds and many types of agitators steadily and firmly, the customers can satisfy with it according to different requirements. All spare parts of touching food are stainless steel or dealt with special operation, and they can measure up the national healthful standard.

This machine has good shape, and is operated simply. Safety, healthful and high efficiency, it is suitable for hotels, restaurants, food processing factories and food canteens. It also can be used for the medical and chemical raw material factories.

You use and maintain the mixer correctly, it can give you the satisfied effect for a long time.

Installation and specification

Installation

- The machine must be put in the dry and flat ground, and make sure the machine steadily.
- We can use four screws to fix the bracket, so the mixer will not shake or slope.
- Check the power voltage is suitable for voltage of this mixer or not before using, the ground wire is firm whether or not.
- When the motor of this machine is equipped with 380V, you can ask the professional electricians to fix the electrical source. If you find that running direction is not right, you can change the two wires, besides the ground wire.

Warning: users must install the shell ground wire.

SPECIFICATION





Type	B40	B40	B40A	B40A	B40F	B40F	B40FA	B40FA	B40FA	B40FA
Capacitor (L)	35	35	35	35	40	40	40	40	40	40
Power Supply (V)	220-240/380~	110-120~	220-240/380~	110-120~	220-240/380~	110-120~	220-240/380~	110-120~	220-240/380~	110-120~
Input Power (W)	1500	1500	1500	1500	1500	1500	1500	1500	1500	1500
Mixing Speed (r.p.m)		483	580	483	580	483	580	520	580	580
		165	198	165	198	165	198	187	198	198
		106	127	106	127	106	127	120	127	120
										238/82/52
Maxflour Capacity(kg)	8	8	8	8	9	9	9	9	9	9

FIGURE 8 TURNING PLATE AND MIXING AXLE



	Description	Qty
1	Inner gear	1
2	Screw	6
3	Nut M14	1
4	Spring gasket 14	1
5	Gasket 14	1
6	Planetary gear	1
7	Bearing 6204	1
8	Turning plate	1
9	Spring gasket	1
10	Nut	1
11	Safe net	1
12	Bearing 6206	1
13	Oil seal 35*56*12	1
14	Key 6*16	1
15	Mixing axle	1
16	Pin 10*37	1

FIGURE 7 BOWL LIFTER UNIT

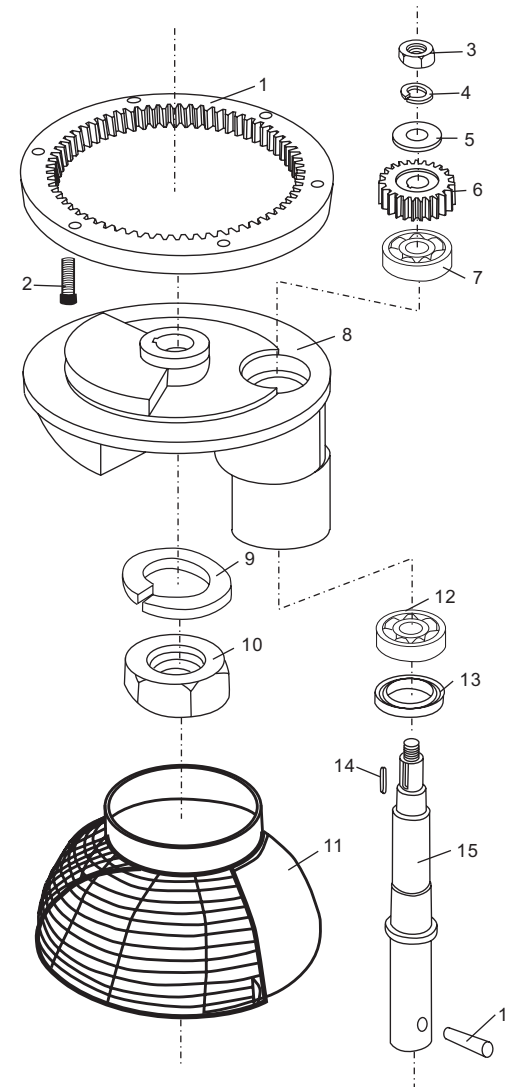
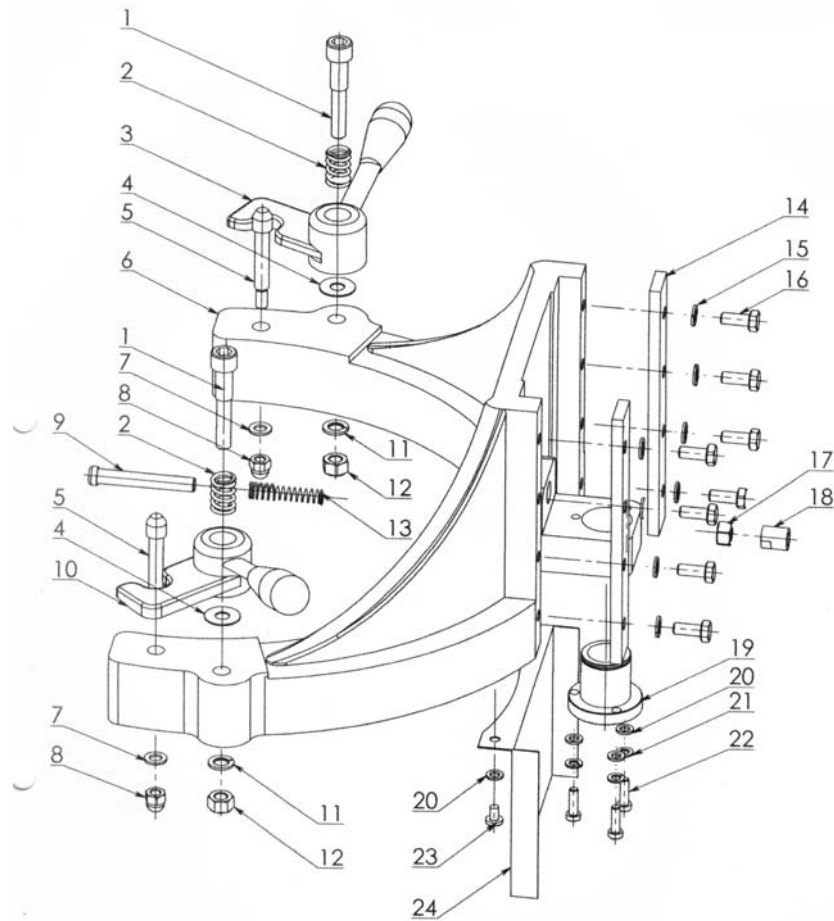

Description	Qty	Description	Qty	Description	Qty
1 Screw	2	9 Switch mandril	1	17 Nut M10	8
2 Spring	2	10 Handle(right)	1	18 Mandril nut	1
3 Handle(left)	1	11 Spring gasket 10	8	19 Copper nut	1
4 Gasket 25*10*1	2	12 Nut M10	2	20 Gasket 6	4
5 Screw	2	13 Mandril spring	1	21 Spring gasket 6	3
6 Arm	4	14 Press bar	2	22 Screw M6*20	3
7 Gasket 8	1	15 Spring gasket 8	8	23 Screw M6*10	2
8 Nut M8	2	16 Screw M8*20	8	24 Stand board	1

OPERATION INSTRUCTION

		<p>➤ Before using, please check power supply if it match your machine and be sure ground wire is eliable.</p>
		<p>➤ Before testing, please take mixing device off first, in order to avoid damage machine which is match moving direction. It's necessary to change the three-phase machine if the moving direction is not match with arrow.</p>
<p>OFF</p>		<p>➤ For changing the speed: Please stop machine first before change speed in order to avoid damage gear box.</p>
		<p>➤ Mixing: according to the different mixing-material. Choose the different mixing devices and speed.</p>
A		<p>➤ A: Be suitable for mix and stir butter, eggs, and work with in high speed, working time is less than 15 minutes.</p>
B		<p>➤ B: Be suitable for mix and stir stuffing and raw material, and work in middle speed, working time is less than 20 minutes.</p>
C		<p>➤ C: middle position is suitable for mixing dough, working time is less than 30 minutes. Flour water quantity is 40%-50%.</p>

✳ In order to keep safety, when using Mixing device I/II/III, Please pay attention to insert their grooves which are from the handles into the spiral axle pin separately. Furthermore, rising the bowl to the highest position, so that the edge of the bowl is higher than Mixing device I/II/III working position.

FIGURE 1 Center axle

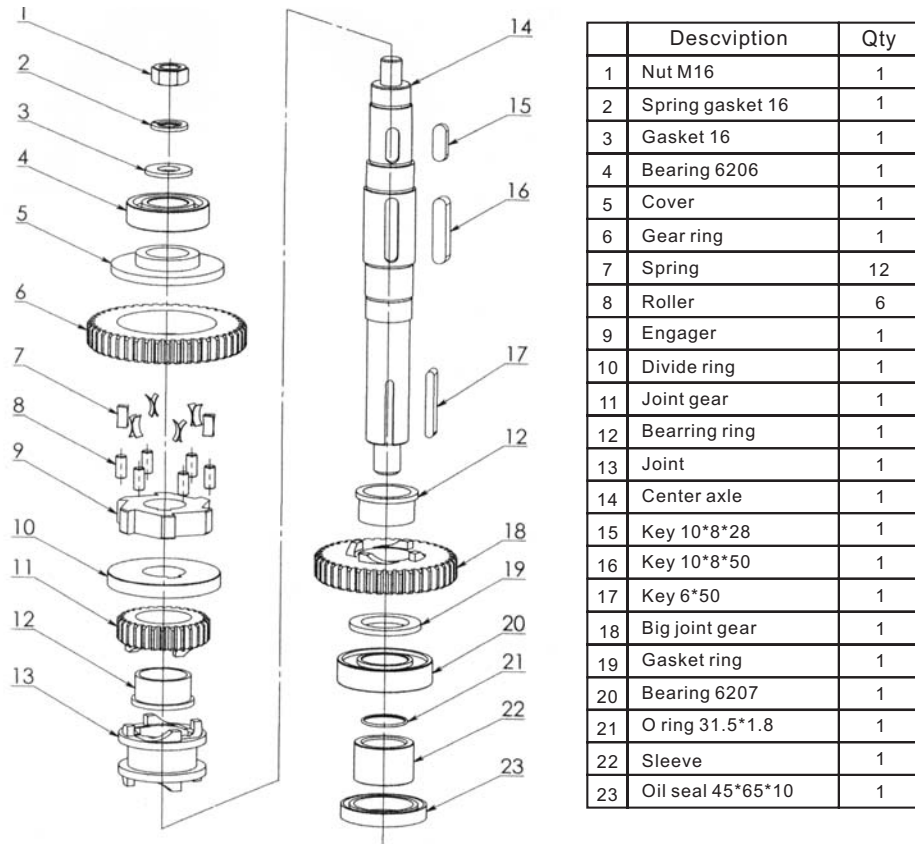

FIGURE 6 Speed shaft

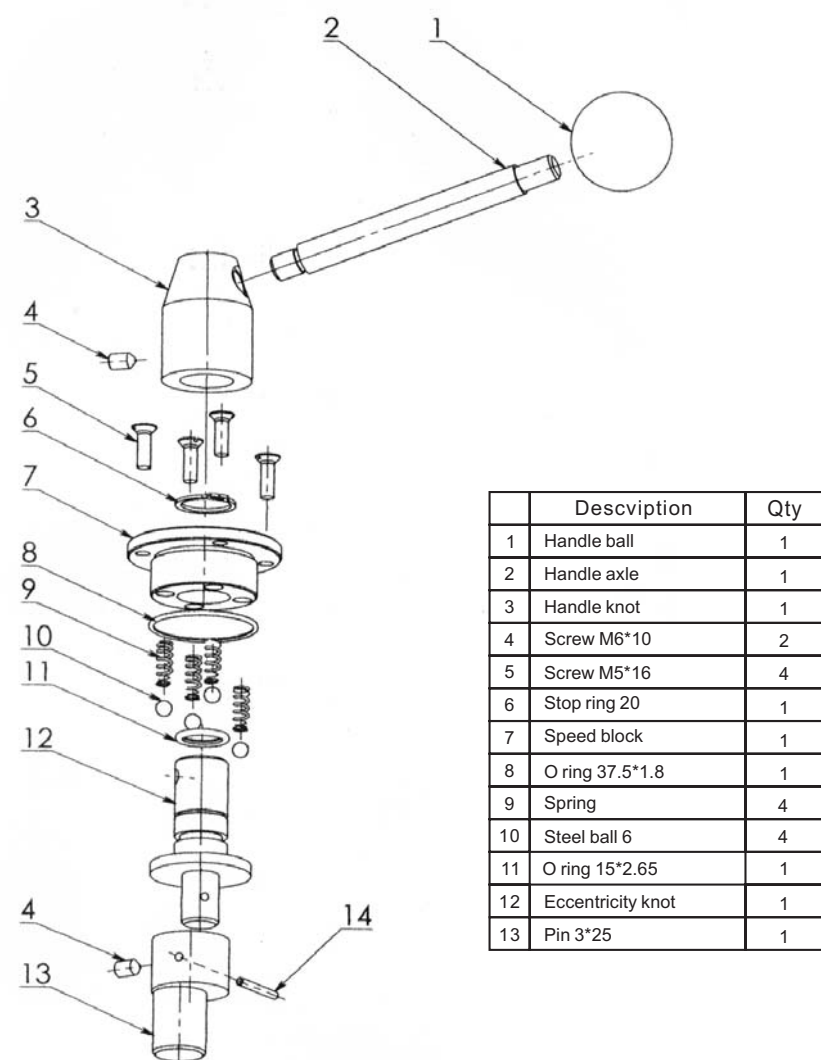
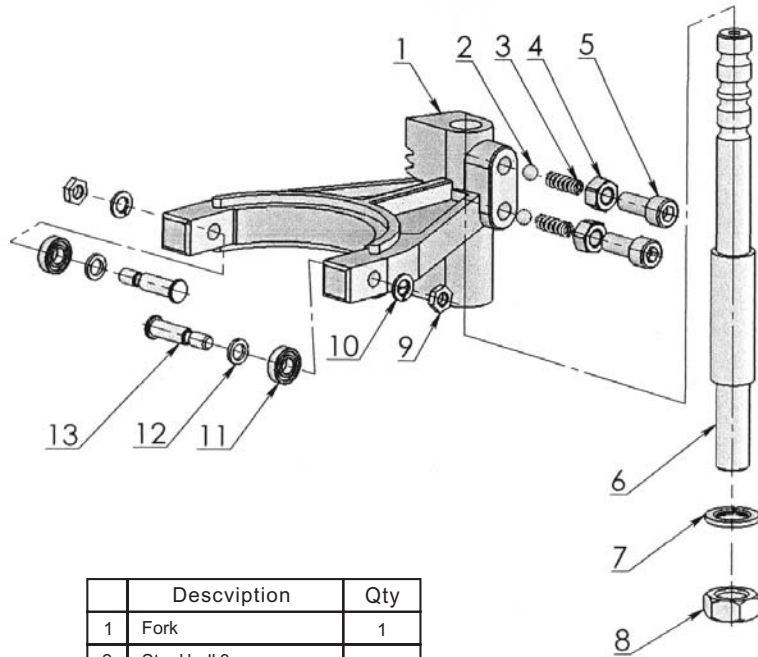
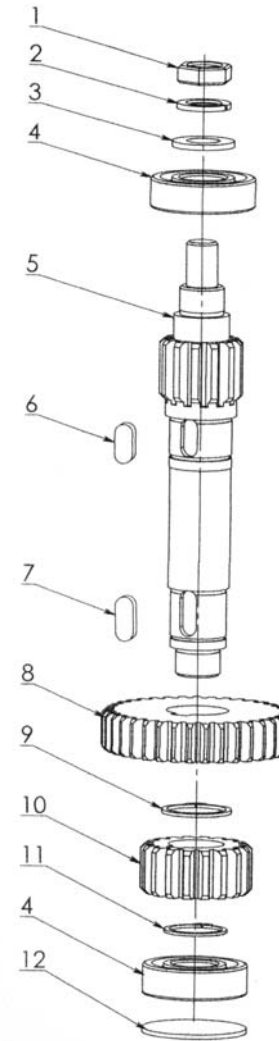

FIGURE 5 Fork



	Description	Qty
1	Fork	1
2	Steel ball 8	2
3	Spring	2
4	Nut M10	2
5	Screw M10*25	2
6	Forkr axle	1
7	Spring gasket 18	1
8	Nut 18	1
9	Nut 8	2
10	Spring gasket 8	2
11	Bearing 699Z	2
12	Gasket ring	2
13	Fork small axle	2

FIGURE 2 Gear axle



	Description	Qty
1	Nut M14	1
2	Spring gasket 14	1
3	Gasket 14	1
4	Bearing 6204	1
5	Gear axle	1
6	Key 8*7*18	1
7	Key 8*7*20	1
8	High speed gear	1
9	Stop ring 28	1
10	Low speed gear	1
11	Stop ring 25	1
12	Gasket	1

FIGURE 3 Initiative axle

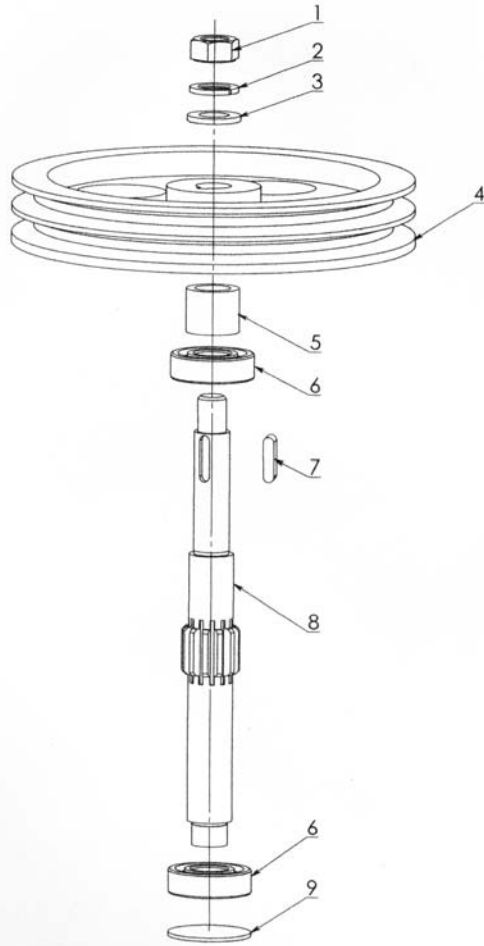

	Description	Qty
1	Nut M16	1
2	Spring gasket 16	1
3	Gasket 16	1
4	Big belt wheel	1
5	Sleeve	1
6	Bearing 6204	1
7	Key 6*24	1
8	Initiative axle	1
9	Gasket	1

FIGURE 4 Motor

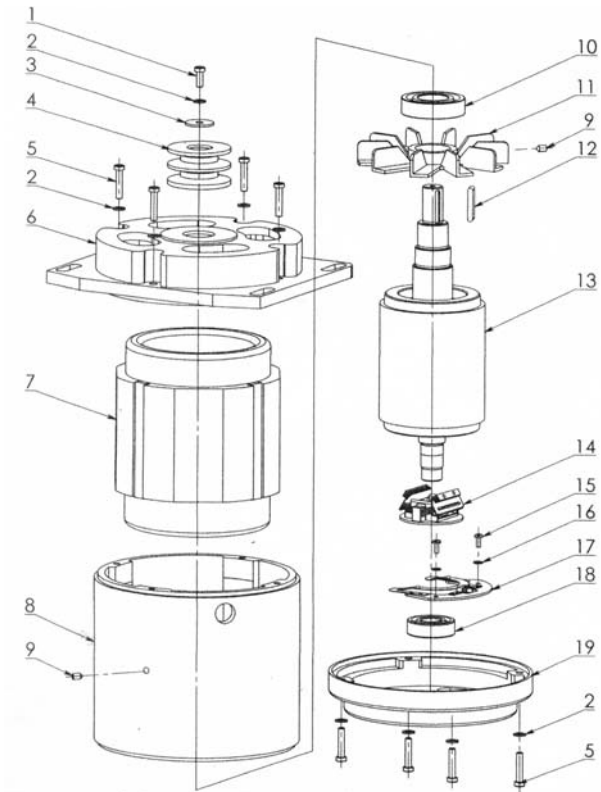

	Description	Qty
1	Screw M6*16	1
2	Spring gasket 16	9
3	Gasket 28*7*2	1
4	Small belt wheel	1
5	Screw M6*30	8
6	Motor above cover	1
7	Motor	1
8	Motor crust	1
9	Screw M6*10	1

	Description	Qty
10	Bearing 6206	1
11	Fan	1
12	Key 5*34	1
13	Rotor	1
14	Switch	1
15	Screw M4*10	2
16	Gasket 7	2
17	Plastic	1
18	Bearing 6204	1
19	Motor below cover	1