

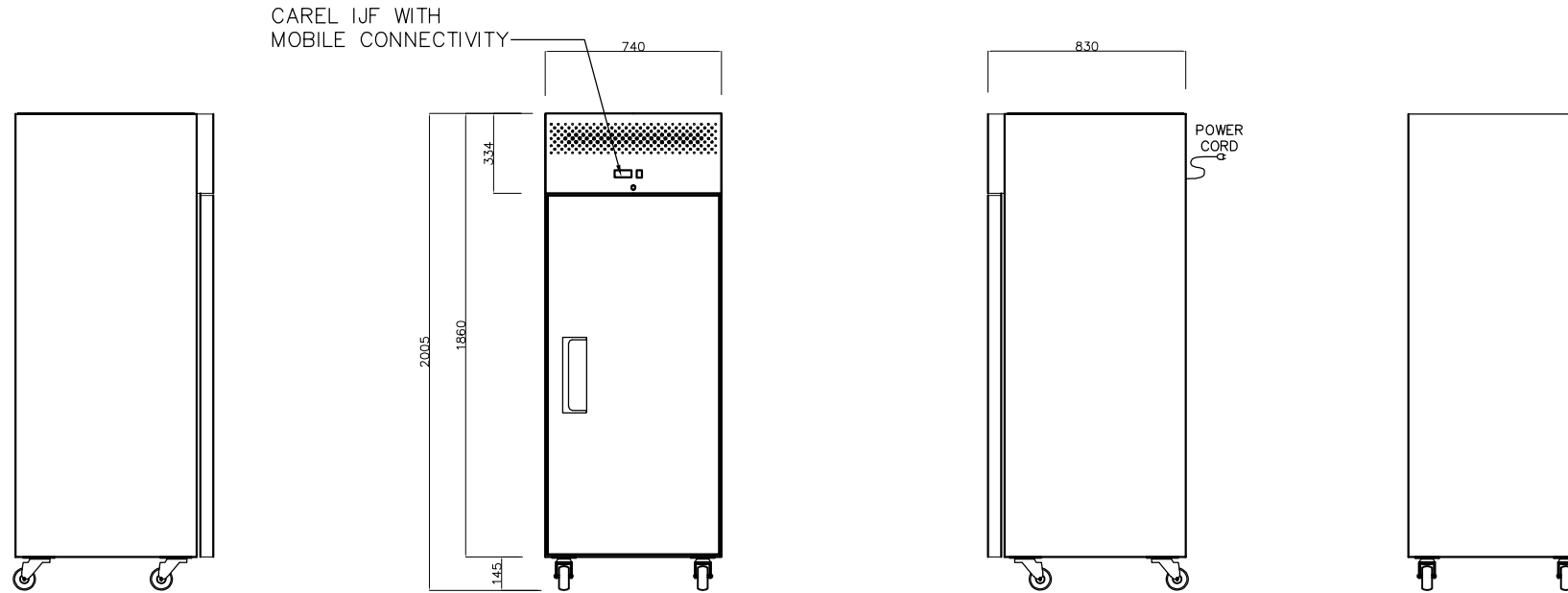

5-11 Garfield Street
 Richmond Vic 3121
 Phone: 03 9416 4667
 Email: sales@agequipment.com.au
 Website: www.agequipment.com.au

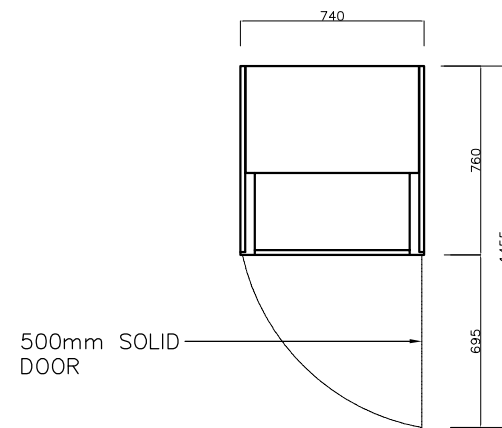

CABINET DIMENSIONS:

	EXTERNAL	INTERNAL
Width (mm)	740	620
Depth (mm)	830	700
Height (mm)	2010	1400
Floor Area(m ²)	0.6142	

ELECTRICAL REQUIREMENTS

Electrical Power (W)	430
Electrical Voltage (V)	220-240
Electrical Ampere (A)	2.8
Electrical Frequency (Hz)	50

VENTILATION REQUIREMENTS

Ventilation will be required at the top of the appliance $\geq 500\text{mm}$.

DIMENSION TOLERANCES:

Allowances for cabinets are to be between -10mm to +10mm unless noted otherwise

MODEL:
GNX650TN

DESCRIPTION:
 650L Upright Single Stainless Steel Door Fridge