

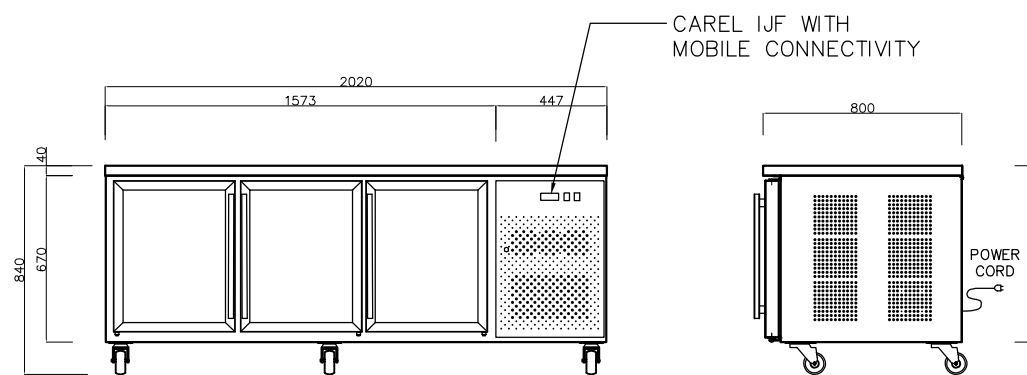

5-11 Garfield Street
 Richmond Vic 3121
 Phone: 03 9416 4667
 Email: sales@agequipment.com.au
 Website: www.agequipment.com.au

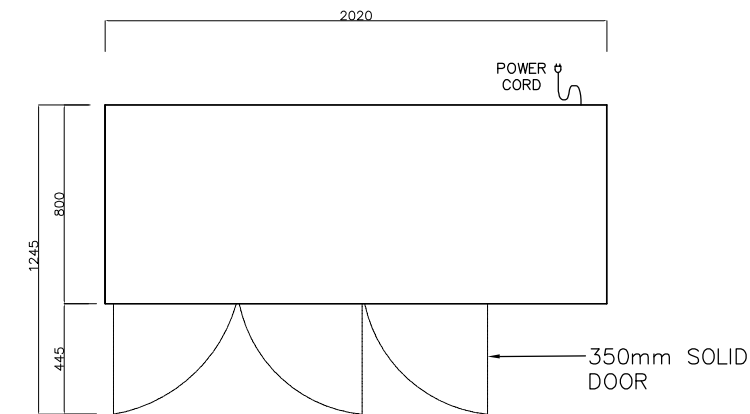
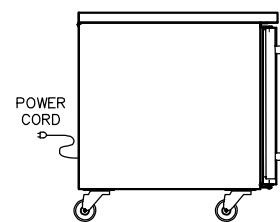
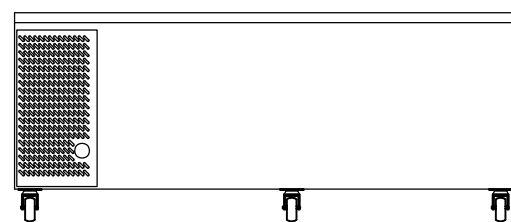

CABINET DIMENSIONS:			
		EXTERNAL	INTERNAL
Width	(mm)	2020	1455
Depth	(mm)	800	680
Height	(mm)	850	560
Floor Area	(m ²)	1,616	

ELECTRICAL REQUIREMENTS	
Electrical Power (W)	320
Electrical Voltage (V)	220-240
Electrical Ampere (A)	2.3
Electrical Frequency (Hz)	50

VENTILATION REQUIREMENTS
 Ventilation will be required compressor side or back ≥150mm.

DIMENSION TOLERANCES:
 Allowances for cabinets are to be between -10mm to +10mm unless noted otherwise

MODEL:
PAX3100TNG

DESCRIPTION:
 3 Glass Doors Commercial Worktop / Under Bench Display Fridge 800mm (d)