

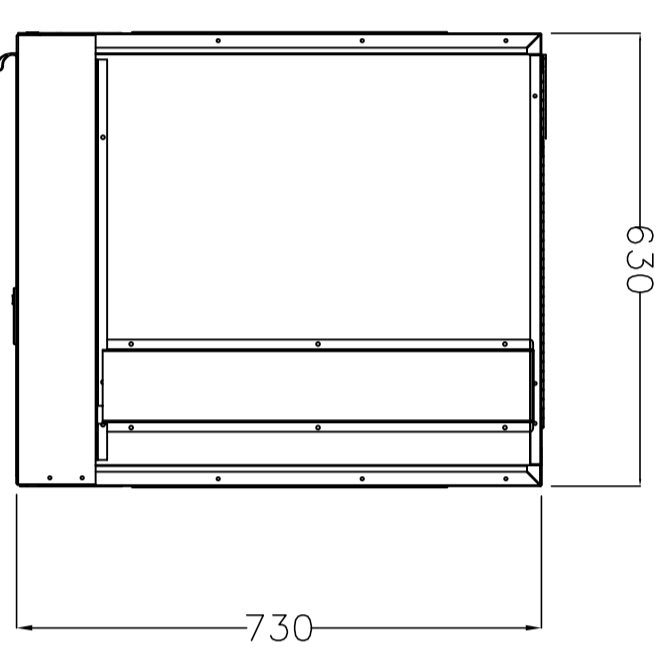

5-11 Garfield Street
 Richmond Vic 3121
 Phone: 03 9416 4667
 Email: sales@agequipment.com.au
 Website: www.agequipment.com.au

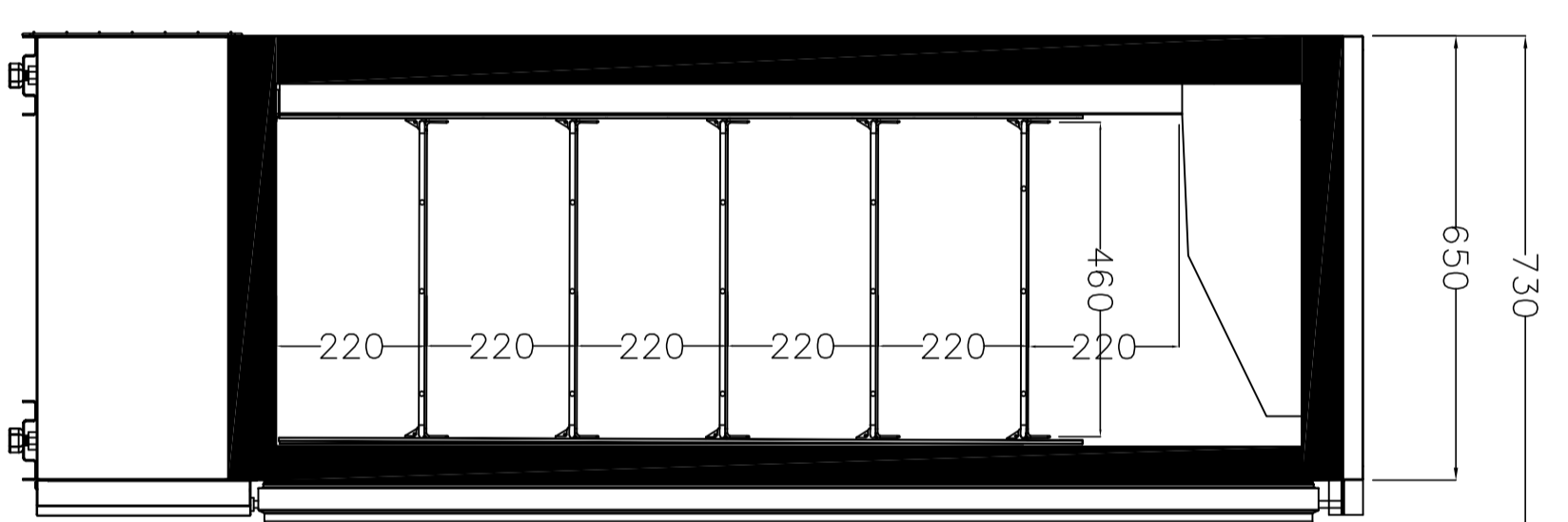
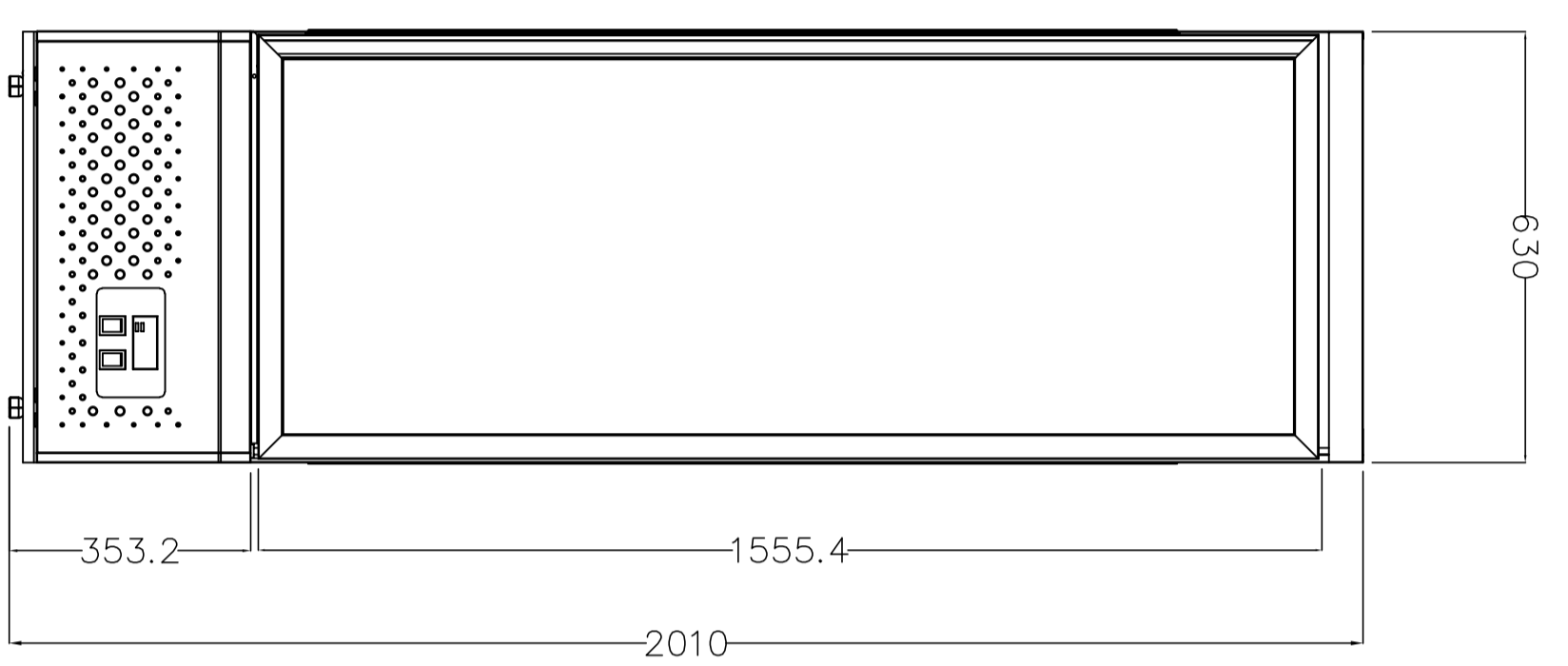
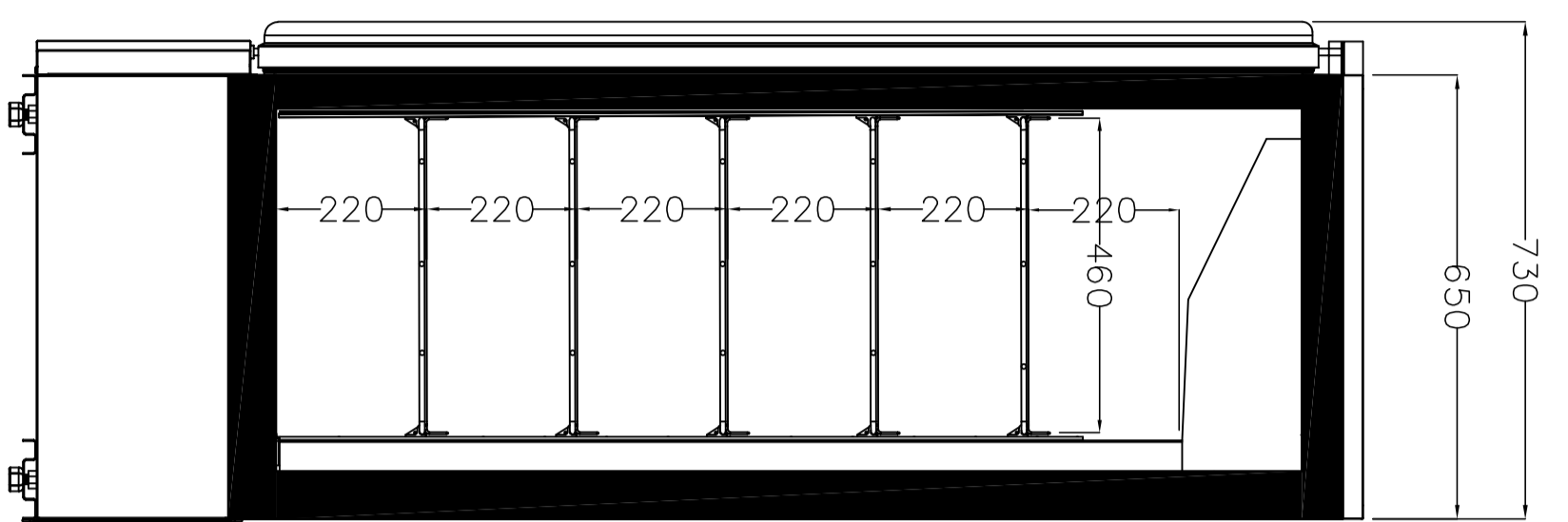

CABINET DIMENSIONS:

	EXTERNAL	INTERNAL
Width (mm)	630	510
Depth (mm)	730	530
Height (mm)	2010	1555
Floor Area(m ²)	0.46	

ELECTRICAL REQUIREMENTS

Electrical Power (W)	426
Electrical Voltage (V)	220-240
Electrical Ampere (A)	2
Electrical Frequency (Hz)	50

VENTILATION REQUIREMENTS

The distance between the back to the wall should be 20cm

DIMENSION TOLERANCES:

Allowances for cabinets are to be between -10mm to +10mm unless noted otherwise

MODEL:

CSB450

DESCRIPTION:

Upright Chiller